

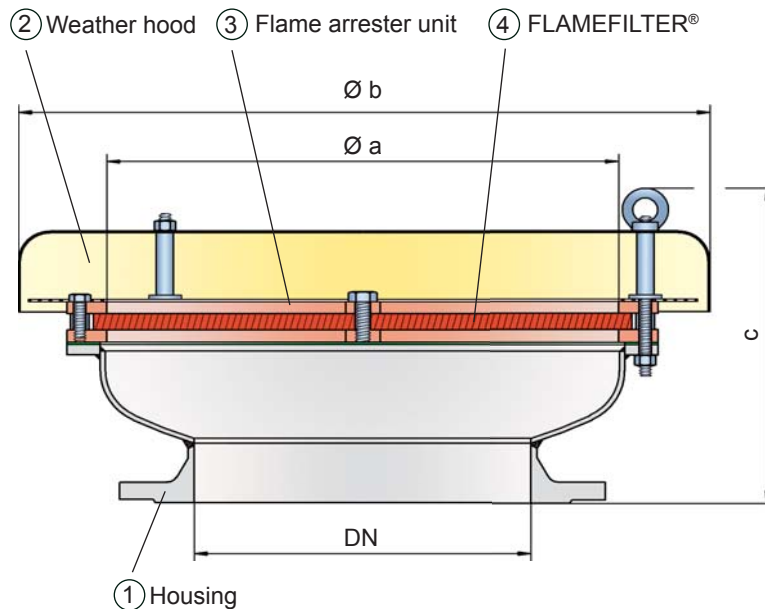

Deflagration Flame Arrester, End-of-Line

PROTEGO® LH/AD



Function and Description

The LH/AD end-of-line deflagration flame arrester provides protection against atmospheric deflagration. The device is typically installed on vent lines of vessels and plants which are not pressurized. For safe application it is important that an endurance burning situation can be excluded, so typically it is installed on vent lines which discharge vapour for a short time period only. The device prevents flame transmission from atmospheric deflagration into the vessel or plant.

The LH/AD consists of a housing (1), a weather hood (2) and the PROTEGO® flame arrester unit (3). The device is equipped with a metal weather hood. A protection screen is installed between the weather hood and the housing to keep animals out. The FLAMEFILTER® (4) gap size will depend on the devices intended use. Detailing the operating conditions such as the temperature, pressure, explosion group and the composition of the fluid, enables PROTEGO® to select the best end-of-line deflagration flame arrester for your application. The LH/AD series end-of-line deflagration flame arrester is available for substances from explosion groups IIA to IIC (NEC groups B to D). The standard design can be used with operating temperature of up to +60°C / 140°F. Several devices of this design are tested and approved for higher temperatures.

Type-approved according to ATEX Directive 94/9/EC and EN 12874 as well as other international standards.

Special Features and Advantages

- weather hood provides protection against environmental impact (harsh weather conditions, bird nests, etc.)
- cost effective device
- available in sizes DN 50 (2") – up to DN 800 (32")
- easy maintenance
- cost effective spare parts
- available for elevated operating temperatures
- protection against atmospheric deflagration

Design Type and Specification

End-of-line deflagration flame arrester, basic design **LH/AD**

Special designs available on request

Table 1: Dimensions

Dimensions in mm / inches

To select the nominal size (DN), please use the flow capacity charts on the following pages

DN	a	b	IIB3	IIC
			c	c
50 / 2"	100 / 3.94	200 / 7.87	170 / 6.69	185 / 7.28
80 / 3"	150 / 5.91	240 / 9.45	180 / 7.09	195 / 7.68
100 / 4"	200 / 7.87	295 / 11.61	220 / 8.66	235 / 9.25
150 / 6"	300 / 11.81	550 / 21.65	260 / 10.24	270 / 10.63
200 / 8"	300 / 11.81	550 / 21.65	260 / 10.24	270 / 10.63
250 / 10"	400 / 15.75	600 / 23.62	355 / 13.98	370 / 14.57
300 / 12"	400 / 15.75	600 / 23.62	350 / 13.78	365 / 14.37
350 / 14"	600 / 23.62	800 / 31.50	405 / 15.94	415 / 16.34
400 / 16"	600 / 23.62	800 / 31.50	400 / 15.75	410 / 16.14
500 / 20"	700 / 27.56	1000 / 39.37	415 / 16.34	430 / 16.93
600 / 24"	800 / 31.50	1200 / 47.24	485 / 19.09	505 / 19.88
700 / 28"	1000 / 39.37	1400 / 55.12	520 / 20.47	545 / 21.46
800 / 32"	1200 / 47.24	1600 / 62.99	560 / 22.05	585 / 23.03

Table 2: Selection of explosion group

MESG	Expl. Gr. (IEC/CEN)	Gas Group (NEC/NFPA)	Special approvals upon request
≥ 0,65 mm	IIB3	C	
< 0,5 mm	IIC	B	

Table 3: Selection of max. operating temperature (°C / °F)

≤ 60°C / 140°F	≤ 100°C / 212°F	≤ 150°C / 302°F	≤ 180°C / 356°F	≤ 200°C / 392°F	≤ 250°C / 482°F	* upon request
(Standard)	X0*	X1*	X2*	X3*	X4*	

Table 4: Material selection

Design	A	B	Special materials upon request
Housing	Steel	Stainless steel	
Weather hood	Stainless steel	Stainless steel	
Protection screen	Stainless steel	Stainless steel	
Flame arrester unit	A	A,B	



for safety and environment



Deflagration Flame Arrester, End-of-Line

PROTEGO® LH/AD

Table 5: Material combinations of flame arrester unit

Design	A	B	Special materials upon request
FLAMEFILTER® cage	Steel	Stainless steel	
FLAMEFILTER®	Stainless steel	Stainless steel	

Table 6: Flange connection type

DIN 2501, Form C, PN 16, from DN 200 PN10	DIN	other types upon request
ANSI 150 lbs RFSF	ANSI	

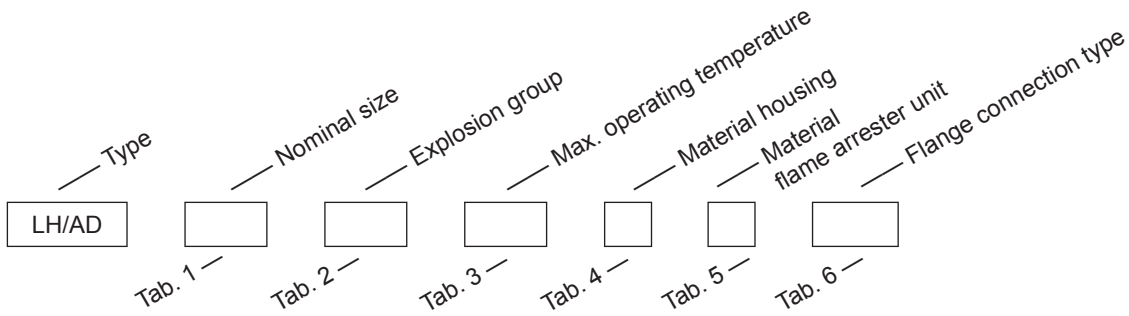

Order example

LH/AD - 800 - IIC - (std) - A - A - DIN

Materials and chemical resistance: Technical information upon request

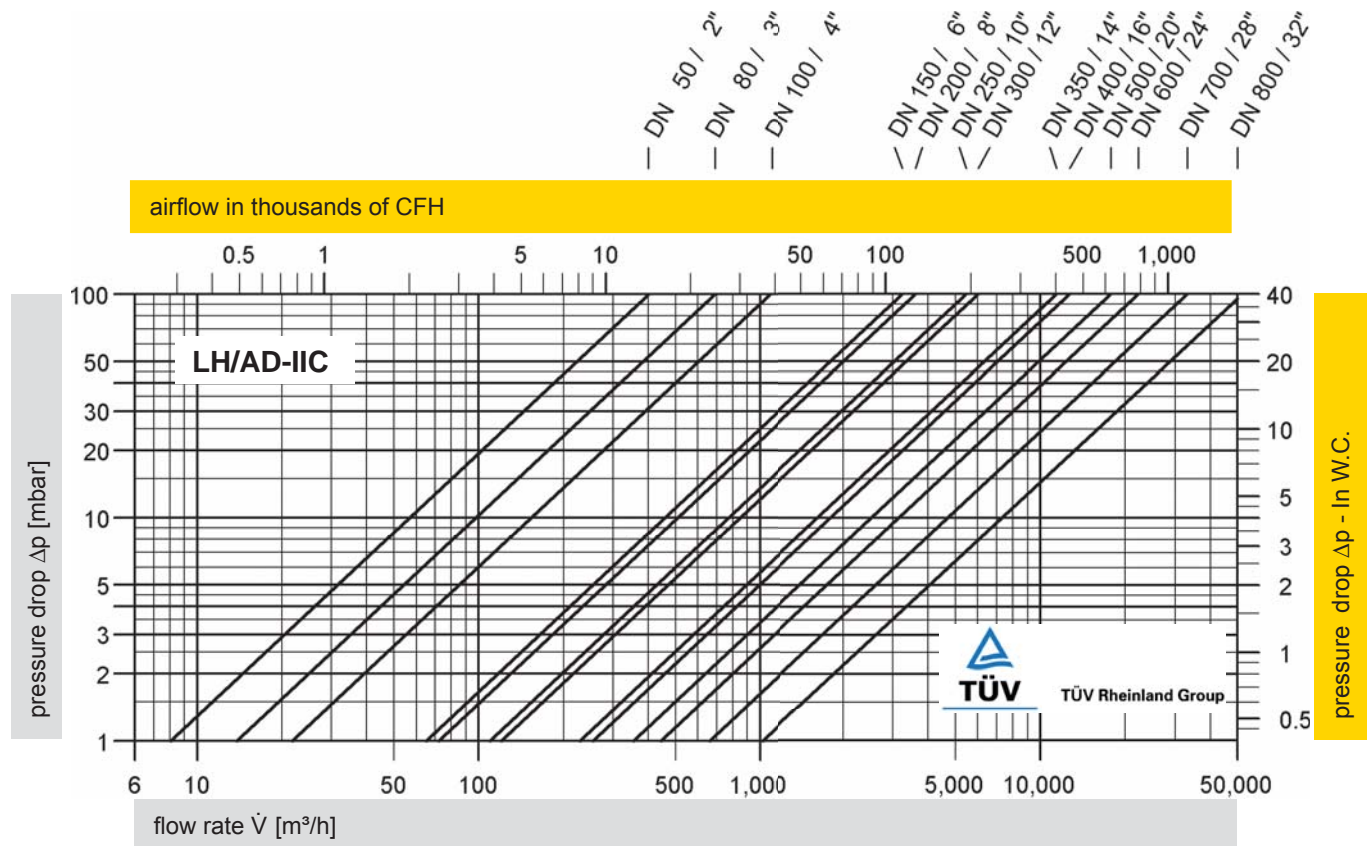
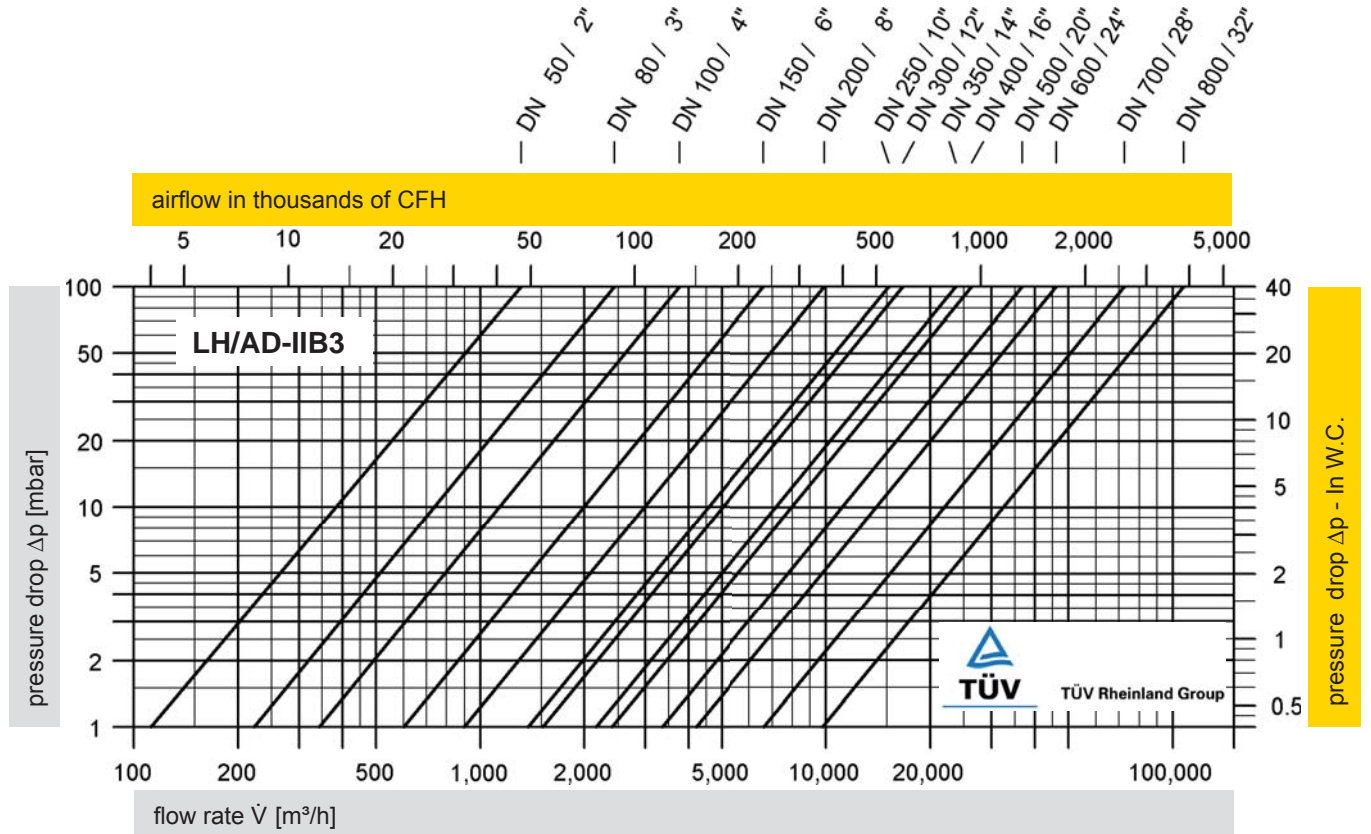

The flow capacity charts have been determined with a calibrated and TÜV certified flow capacity test rig.
 Volume flow \dot{V} in [m³/h] and SCFH refer to the Standard reference conditions of air ISO 6358 (20°C, 1bar).
 Conversion to other densities and temperatures refer to Technical Fundamentals.

